



# The Voice for Illinois Forests

*Acting on issues that impact rural and community forests and promoting forestry in Illinois*

**\*\*IFA Officers\*\***

**President**

Mike McMahan  
mcmahan3465@hotmail.com

**Vice President**

John Edgington  
johnedg@illinois.edu

**Secretary**

Dave Gillespie  
dandgisp@aol.com

**Treasurer**

Susan Romano  
old\_farmstead@yahoo.com

**Past President**

Bill Gradle  
sallygradle@comcast.net

**Executive Director**

Stephanie Brown  
sbrown63@shawneelink.net

## Message from the President

*By Mike McMahan*



As the weather continues to warm, and the threat of that last “freeze” fades into the past, we look forward to a season of growth. Slowly, but surely, we are watching our seeds sprout. We will cultivate, fertilize, and eventually enjoy the harvest as our plans bear fruit.

In IFA, our five goals are like raised beds of activity where we are focusing all of our inputs to produce the best quality outcomes for forestry in Illinois. We don’t have all of our beds in full production yet, but we are making the right amendments to the soil and lining up the best seeds to plant.

**Goal #1** is to promote forest management and help landowners manage forests. Our Technical Advisory Committee has the lead role, as their forestry expertise and the jobs they perform make for fertile ground to grow our educational programs upon. Workshops, field events, publications, and webinars are some of the fruits that we expect to see when the sun shines on this bed.

**Goal #2** is to educate members and the general public. Reaching new people with a message that resonates is the goal of our Marketing Committee. Presenting our message so that people notice IFA, hear about our good works, and support what we’re doing – we are preparing this bed so that it will produce many sprouts!

**Goal #3** is policy advocacy for IL Forests. Our Legislative/Policy Committee is leading the way to make IFA the Voice for Illinois Forests. Working with coalitions whenever possible, we have nudged the Exotic Weed Act through committees toward a needed amendment, we are actively supporting a resolution to establish October as Oak Awareness Month, and we are working with a key lawmaker to explore a supplemental appropriation that would restore operations at the Union Tree Nursery. We are also acting on concerns about funding levels for Illinois Soil & Water Conservation Districts.

**Goal #4** is to understand/engage members and increase membership. Our Membership Committee is leading an effort to better understand why some memberships have lapsed, and how we can coax past members back into the fold. We’re actively seeking partnerships as a way of reaching new people, while exposing our members to the value that other programs offer. I’m especially excited about some new plans on the horizon with the Illinois Arborist Association. Let’s get a little cross-pollination going!

**Goal #5** is efficient and effective IFA governance. Your Executive Committee and Board of Directors are committed to leading a highly functional and financially sustainable organization that will stand the test of time. It is not always easy, but we have a good group of people and a solid plan to take IFA to the next level.

Leading IFA is not without its challenges, but it can be very rewarding to grow an organization. Thanks for your part in our success to date. Many hands make light work! Wishing you an enjoyable and productive growing season.

**\*\*Inside this Issue\*\***

President Message	1
Association News	2
Policy/Program Updates	3
Featured Articles:	5
Improving Oak Regeneration	
Where are the Whippoorwills?	
Commentary	7
Cutting Edge	
Acorns & Walnuts	
History of Conservation	
Resources	8
Featured Tree - NEW!	
Invasive - Oriental Bittersweet	
Wood Project - Purple Martin	
... and more!	

**IFA Website**  
[www.ilforestry.org](http://www.ilforestry.org)

## Executive Director Notes

by Stephanie Brown



Hello everyone! Things are certainly heating up outdoors and behind the scenes in IFA. There's plenty to do!

Mike mentioned our five goals. Each one represents a front of activity, and gradually we are making progress on each one. My contract being part-time, and our volunteer force limited, we have to keep it real. But, we are definitely making progress!

On the membership front, we are looking forward to the "bump" that we usually see when the IDNR biennial renewal mailing goes out to all of the landowners who have forest management plans and participate in the tax-saving Forestry Development Act (FDA) program. It's a great way to reach people who are interested in forestry, but unaware that IFA exists to serve and represent them. This go-around we are adding a new twist that relates directly to our #1 goal of promoting forest management.

IFA has received approval for the first phase of a project that will offer a free e-newsletter to any FDA landowner who chooses to subscribe. Its purpose will

be very specific - to extend information that will encourage landowners to stay in compliance and follow-through with their forest management plans. We hope this will make the jobs of foresters a little easier - more information going out, less intervention needed at the time of program renewal. A lot can happen - or not - in the two+ years between renewals if there is limited or no contact.

Naturally, we would love to count all 10,800 FDA landowners among our membership ranks, but if we want to get serious about fulfilling our charitable mission, we need a way to reach and engage a lot more landowners with the message of good forest management.

**Mark Your Calendar!**  
**September 25-26, 2015**  
**IFA/Tree Farm  
Joint Annual Meeting  
and Field Day**  
**Near Effingham**

The newsletter you are reading will continue to be the gold standard. Those who step up and join IFA get a newsletter that is more extensive and varied in its content to appeal to our diverse membership. We need our members to see IFA as a good cause that enhances forest health and productivity statewide.

As the current fiscal year winds down, we look forward to completing work on the Profiles in Forestry and Across the Miles projects, also funded by the Forestry Development Council. Soon we will have a collection of short photo stories to help people understand the depth and breadth of what we represent.

Looking toward the fall we have some exciting things on the horizon. Our 10th Annual Meeting theme will be "Woods and Wildlife," featuring talks about managing forests for wildlife, deer population and hunting trends, wood identification and fun facts, and woodland wildflower insights. We adjusted our normal regional rotation to coincide with the annual Tree Farm Field Day, which happens to be on IFA Board Director Tony (and Jill) Kreke's Tree Farm. Wait till you see what they have planned! It is going to be one for the books.

Planning is also underway for the first ever Oak Awareness Month, which has been dubbed OAKtober. We hope to offer a program as part of the IL Arborist Association Annual Conference in Tinley Park, along with special events in Central and Southern Illinois. Stay tuned!

## Secretary Comments

by Dave Gillespie

When many people think of Illinois, they quite often envision corn and soybeans as far as the eye can see, cattle and hogs, flat prairies, and large cities such as Chicago, Rockford, and Peoria. What they sometimes don't see are 4.79 million acres of some of the finest hardwood forests in the U. S., plus the "urban forest" in the large cities mentioned.

The IFA worked with the Illinois Forestry Development Council who commissioned a study and report on the forest product industry in Illinois. The resulting report divided the forest product industry into four parts: logging, solid wood products, pulp and paper,

and wood furniture manufacturing. Two related sectors were also noted; miscellaneous forest products and urban forests.

The bottom-line, add it all together, the forest product industry exceeded \$23.08 billion in Illinois. Employment totaled 131,550 full or part-time jobs with an associated annual payroll of \$8.10 billion. Illinois' forest products industry also generated over \$2.49 billion in total tax revenue in 2010 to federal, state, and local governments.

These are just some of the facts about forestry in Illinois that are little known to most of our neighbors. Help spread the word about our renewable forest resources.

**Find IFA on  
Facebook!**



Members and their loved ones who use Facebook are urged to "Like" and "Share" the Illinois Forestry Association page, as well as our occasional posts. This doesn't replace any of our regular forms of member communication, but offers a new way for people within and outside IFA to learn about forestry and IFA. Our success depends on the extent of members' sharing, so thanks in advance for helping to grow our audience!

[www.facebook.com/ILForestry](http://www.facebook.com/ILForestry)



## State Forester's Report

Tom Wilson

Our forest management program is adopting new rules

to guide participation and incentives under the Illinois Forestry Development Act. New administrative rules will go to 10-day internal DNR review and then to the Joint Committee on Administrative Rules (JCAR) approval process by the printing of this newsletter. Our Division of Forest Resources is committed to delivering comprehensive forest stewardship statewide and continues to cooperate with all private landowners who choose to enhance, protect and yield more and improved benefits from their forestland.

The state tree nurseries are poised, despite the current lack of necessary staff at Union Nursery, to expand to meet demand for native forbs, wetland plants and nursery stock. In 2016, the state nurseries will charge for all stock to all customers and a website is being developed to allow for easy online ordering and payment. A long range plan is currently being drafted to assure a sound future to the nursery operations and continued production of native and other important plants for conservation across Illinois.

Urban & Community forestry grants continue to be available to municipalities to foster and develop tree programs and proper tree care and planning. Communities may apply for this annual grant program offered by the DNR and our US Forest Service (July 1 deadline this year) by contacting the Forestry Division or visiting our website. Grants of up to \$15,000 with a required 50% match are allowed.

Illinois recently hosted 36 Cooperative Forest Management foresters from 20 northeastern US states and the US Forest Service to discuss exchange and improve the national effort to manage forests under the Forest Stewardship Program and its guidelines. The meeting, which rarely comes to Illinois, was hosted at Pierre-Marquette State Park near Grafton, Illinois where we showcased active forest stewardship and forest management at the McCully Heritage Project stewardship forest and the Principia College FSC certified forests.

The Illinois state government and DNR are still wrestling 2016 budgets as we approach the new state fiscal year and we anticipate that funds and projects will be very limited the next two years. That said, we continue to make available important information, expertise, core programs and opportunities for the full range of important aspects of forestry including fire use and protection, wildlife habitat, urban forests, forest stewardship, timber and forest health. Enjoy your Illinois summer.

### Illinois Exotic Weed Act Update

SB681 proposes a much needed update to the Illinois Exotic Weed Act by adding several new invasive species to the regulated list, including the exotic bush honeysuckles, exotic knotweeds, teasels, exotic olives, salt cedars, poison hemlock, giant hogweed, Oriental bittersweet, and lesser celandine. At press time this bill had passed both the Senate and House, and was working its way to the Governor's desk to be signed into law. IFA interacted with the legislative process on numerous occasions by submitting electronic witness slips in favor of the bill's swift passage.

### Invasive Species Awareness Month

For the sixth straight year, May was recognized as Illinois Invasive Species Awareness Month. Over 160 events were held across the state to help raise awareness and knowledge about invasive species. The capstone event was an Invasive Species Symposium, held on May 28th in Champaign. A joint resolution declaring the monthlong observance has been making its way through the IL General Assembly.

<http://illinoisiam.blogspot.com/>

<http://invasive.org/illinois/>

### IFA Regional Directors

**Carol Bryant**  
Mt. Olive, IL  
618-444-3864  
[cabryant2@gmail.com](mailto:cabryant2@gmail.com)

**Tom Desulis**  
Frederick, IL  
(217) 322-6151 - Home  
(217) 248-8288 - Cell  
[tdesulis@gmail.com](mailto:tdesulis@gmail.com)

**John Dickson**  
Makanda, IL  
(618) 457-4871  
[jwd4a@frontier.com](mailto:jwd4a@frontier.com)

**Edward Eppy**  
Metamora, IL  
(309) 256-3430

**Jim Hynes**  
Pleasant Plains, IL  
217-502-4528  
[hynesfarm@gmail.com](mailto:hynesfarm@gmail.com)

**Jim Kirkland**  
Stonefort, IL  
618-695-3383  
[1984kirk@gmail.com](mailto:1984kirk@gmail.com)

**Anthony Kreke**  
Effingham, IL  
(217) 536-5601  
[tonynjill@frontiernet.net](mailto:tonynjill@frontiernet.net)

**Dan Schmoker**  
Springfield, IL 62443  
217-529-0061 – Home  
[danwalnut1@gmail.com](mailto:danwalnut1@gmail.com)

**Roger Smith**  
Benton, IL  
(618) 927-2057  
[smithtreefarmllc@hotmail.com](mailto:smithtreefarmllc@hotmail.com)

**Alan Wolfgang**  
Hinsdale, IL  
[alan\\_wolfgang@outlook.com](mailto:alan_wolfgang@outlook.com)





### Soil & Water Conservation Districts Face Uncertain Future

by Stephanie Brown

Like many other state-supported institutions, Illinois' 97 Soil & Water Conservation Districts (SWCDs) are stretched out over a barrel. Make that an abandoned well.

Statewide, SWCDs face a funding shortfall of \$2.8 million – 37% of what they needed in FY2015 to make ends meet. If the suspended funds are not restored, most SWCD Boards around the state will be forced to dismantle their work force.

SWCDs are already making do with 30% fewer staff than they employed just 8 years ago. Although most Districts saved for a rainy day, it has been raining long enough to deplete savings accounts. A downpour of this magnitude has the potential to wash away the farm, so to speak.

Soil & Water Conservation Districts are local units of government, typically co-located with the USDA Natural Resources Conservation Service, in USDA Service Centers around the state. Districts serve as a local point of contact for landowners wishing to address resource concerns on their property. They assist in delivering programs that prevent erosion and protect water quality – from farmland to forest to urban development settings.

According to the Association of Illinois Soil and Water Conservation Districts (AISWCD), "each District office is responsible for bringing state and federal agency funding to both rural and urban citizens in Illinois. Unlike most state-funded agencies, SWCDs return to the local economy an average of \$23.57 for every \$1 spent for their operation. SWCD programs are capable of adding more than \$400 million to the State's economy every year, but if Districts are forced to close, the valuable services they provide to the residents of Illinois will disappear completely."

SWCDs have been a critical part of our nation's conservation infrastructure since their formation during the Dust Bowl era. They are important locally because they can still provide attention and service at the county level. Their programs have been tailored to serve local schools, local landowners, and the community at large.

In addition to providing technical service and information about federal and state conservation programs, District staff offer services and organize events throughout the year, including Arbor Day tree planting campaigns for area students, Ag Discovery Days, Conservation Fairs, annual poster and photo contests, native tree sales, fish sales for pond stocking, various educational workshops, and much more.

The Illinois Forestry Association recognizes the tremendous value of the SWCD network and the dedicated staff and board directors behind it. We heartily appreciate their unique role in conservation - and the land ethic that they have always sought to foster at the local level.

SWCDs are vulnerable because we are only talking one or two jobs in a given county – in a very tough budget climate. People might not kick up enough fuss, since we've all been conditioned to expect cuts. That's where partners come in. We have to speak up and be advocates, or cuts to the causes that matter most to us will surely happen.

Contact your state legislators, along with any other strategic contacts you may have, and ask for restoration of the \$2.8 million in FY2015 funds that have been suspended in the Governor's Office of Management & Budget and Illinois Department of Agriculture's proposed budget.

Let's not let these dedicated public servants fall down the one abandoned well that they were unable to help seal.

<http://www.illinois.gov/government/Pages/LegislativeBranch.aspx>

<http://www.aiswcd.org/>

### IFA Technical Advisors

#### **Kurt Bobsin**

IDNR -Forestry Regions III-IV  
217/784-4730 x-224 (office)  
[kurt.bobsin@illinois.gov](mailto:kurt.bobsin@illinois.gov)

#### **Jay Hayek**

University of Illinois  
217-244-0534 (office)  
[jhayek@illinois.edu](mailto:jhayek@illinois.edu)

#### **Wade Conn**

State Forester, USDA-NRCS  
217-353-6647 (office)  
[wade.conn@il.usda.gov](mailto:wade.conn@il.usda.gov)

#### **Paul Deizman**

IDNR Forest Resources  
217-782-3376 (office)  
[paul.deizman@illinois.gov](mailto:paul.deizman@illinois.gov)

#### **John Groninger**

Southern Illinois University  
618/453-7462 (office)  
[groninge@siu.edu](mailto:groninge@siu.edu)

#### **Chris Whittom**

IDNR Forest Resources  
217-785-8264 (office)  
217/280-3659 (cell)  
[chris.whittom@illinois.gov](mailto:chris.whittom@illinois.gov)

#### **John Edgington**

University of Illinois (retired)  
217/840-5162  
[johnedg@illinois.edu](mailto:johnedg@illinois.edu)

#### **Susan Romano**

Western Illinois University  
309/333-1568  
[s-romano2@wiu.edu](mailto:s-romano2@wiu.edu)

#### **Dan Schmoker**

IDNR Forest Resources (retired)  
217/529-0061 (home)  
[danwalnut1@gmail.com](mailto:danwalnut1@gmail.com)

#### **John Dickson**

618/457-4871  
[jwd4RA@frontier.com](mailto:jwd4RA@frontier.com)

#### **Stan Sipp**

217/489-9003  
[sklipp@illinois.edu](mailto:sklipp@illinois.edu)

# Improving Oak Regeneration with Prescribed Fire and Thinning

by Eric Holzmüller, John Groninger  
and Charles Ruffner, Department of Forestry,  
Southern Illinois University

Oaks are declining in dominance in productive stands across Illinois because regeneration is often inadequate to replace dying or harvested trees. The understory and midstory within mature oak forests, is typically now dominated by shade-tolerant, mesophytic tree species. When a disturbance of the canopy does occur, these mesophytic species tend to capture site resources resulting in decreased oak dominance in the next stand.

Prescribed fire and light thinning are frequently recommended by foresters in the area to facilitate oak regeneration. While anecdotal evidence supports these management prescriptions as helping oak seedlings become more dominant in the understory, there is a lack of statistical data to confirm the long-term value of these prescriptions in combating the decline of oaks in Illinois forests. In the early 2000s, a consortium of state forest management personnel, private forest landowners, and university researchers established a series of sites in southern Illinois to assess the long-term impacts of light thinning and prescribed fire on oak regeneration. These sites are located on private and public lands and have been host to numerous demonstration days and field tours over the years. Each site is divided into four units that received one of four management treatments: 1) thinning only 2) burning only, 3) thinning and burning combined, or 4) no treatment (control).

The thinning treatments removed all trees < 8 inches at DBH (except individuals of species that produce hard mast, e.g. oaks and hickories) in 2002 and resulted in an estimated reduction of 20-30% of the original basal area. Stumps were treated with Garlon 4 herbicide, (Triclopyr - 16% a.i.) immediately following cutting. Prescribed burning



*Thin and burn treatment at Dixon Springs State Park*

treatments were applied in the growing season (spring) of 2002 & 2006 and were low- to moderately-intense surface fires. By 2012, overstory basal area was similar among all treatments, but overstory stem density was about 40% lower in the thinning only and thinning and burning combined treatments. Overstory oak and hickory comprised >86% of basal area throughout all treatments

Ten years after thinning and six years after the last prescribed burn, we found that red and white oak regeneration stems had over twice the height and diameter in the combined thinning and burning treatment compared to the control treatment. White oak regeneration density was two times greater in the thinning and burning combined treatment compared to the control treatment. However, thinning only or burning only treatments alone did not result in larger oak stems or greater densities compared to the control. These results are consistent with other studies in the central hardwood region that found burning or thinning alone does not facilitate oak regeneration in mature stands and more intense treatments more effectively facilitate oak regeneration.

While the thinning and burning combined treatments have started the oak regeneration process, stocking is still relatively high. Without further management the advanced oak regeneration will not likely reach the overstory. At this stage we would recommend the use of a two-cut

shelterwood system to give the developing oak saplings the light they need to progress to canopy dominance in order to maintain the oak component in the future forest overstory. The advanced oak regeneration component in this treatment has already become visibly distinguishable from untreated stands and should be markedly more responsive to subsequent overstory removal.

### UPCOMING EVENTS ABOUT OAKS...

#### Acorn Ecology

June 6, 2015 9:00 a.m.-12:00 p.m.  
The Morton Arboretum, Lisle, Illinois  
A large oak tree will produce hundreds of thousands of acorns in its lifetime; only one will survive and grow to be a tree of the same size. Learn about strategies to stimulate oak reproduction, the fate of the unfortunate oaks, and oak seedlings. Explore how reducing stand vegetation can aid oak ecosystem management. [Register now.](#)

#### Oaks, Insects, and Animals

July 19, 2015 9:00 a.m.-12:00 p.m.  
The Morton Arboretum, Lisle, IL.  
Discover the animals and insects that use oaks for food and shelter. Join us this summer to marvel at the diversity of species that depend on oaks and the different ways that oaks, animals and insects interact. Gain a deeper understanding of the role of oaks in IL ecosystems and why their conservation is so important. [Register now.](#)



## Where have all the Whip-poor-wills gone?

by Tracy Boutelle Fidler

“Where have all the whip-poor-will’s gone?” has become a common question posed to those who give tours of Illinois’ forests, as a lot of people miss hearing their distinctive nighttime song.

The answer is quite simple: They whip-poor-wills no longer have what they need in our forests.

Every bird needs something different. Eastern whip-poor-wills, for example, are night-time insect hunters. They need moonlight to forage. That means they need forests that are open, as shady, closed forests block moonlight. But, they don’t like big, wide open areas either.

### Whip-poor-wills Need More Open Forests

Take away a forest’s structure, and you risk losing some of its birds. That’s the finding of analyses by Partners in Flight and Central Hardwoods Joint Venture, two coalitions focused on American birds with declining populations.

“As forest canopies close, you get declining species,” said Larry Heggemann, who works with the Central Hardwoods Joint Venture to raise awareness about the plight of birds that depend on more open forests and woodlands.

“The birds that use open forest woodland habitat ... are the ones that are declining the most in our region. They need periodic disturbances, or something to cause gaps in the trees,” Heggemann said.

If you’re not hearing the tell-tale nighttime call of the whip-poor-will, likely, the lack of open habitats and closed tree canopies are to blame. Central Hardwoods Joint Venture lists the whip-poor-will on its list of priority forest-woodland species, along with blue-gray gnatcatcher, Eastern wood-pewee, wood thrush, and 12 others.

*The whippoorwill  
is coming to shout  
And hush and cluck  
and flutter about:  
I hear him begin  
far enough away  
Full many a time  
to say his say  
Before he arrives  
to say it out.  
— Robert Frost*

### Illinois’ Forests

Scientists who study birds often group them based on the kinds of habitat they prefer: canopies, midstory, shrubs, ground or tree cavities.

For Illinois to be a home to a variety of birds, then, it needs a diversity of forest habitats.

Managing forests for birds requires a careful review of the scientific literature, as information and knowledge about the needs of birds has expanded a lot in the last decade. We know, for example, that birds prefer large, unbroken blocks of forest. The more expansive the forest, the less parasitism there is from cowbirds.

For a long time, scientists thought this meant that our forests should be undisturbed. It wasn’t until bird surveys revealed that some birds — like the whip-poor-will — were on the decline that scientists looked more closely at what was causing it and what could be done. What they learned is that many of these declining birds depended on more open, forested habitat.

Scientists now know that birds require a diverse mix of forest communities to thrive. Introducing disturbance into the forest — through prescribed fire or tree removal — are two ways to do that. And, the good news is that removing trees inside a forest block does not create forest edges that could be exploited by cowbirds.

### Interested in Learning More?

The Cornell Lab of Ornithology’s online bird guide shows what kind of habitat each species prefers. Look for birds with the open woodland designation to see what kind of birds near you might depend on a more open forest. Or, check out the list of priority bird species on the Central Hardwood Joint Venture’s web site.

Like [Southern Illinois Forest Management](#) on Facebook.



## CUTTING EDGE

*Dr. Susan Romano, Associate Professor, Departments of Biological Sciences and Geography at Western Illinois University*

Welcome to this new IFA newsletter series, the "Cutting Edge", providing new ideas and innovative approaches to forest land management. This first article will cover a tool used by Driftless Land Stewardship (DLS), a natural areas consulting firm located in Bagley, Wisconsin. DLS successfully uses a backpack torch method to burn out spot populations of invasive species in woodlands. The species most often treated with this technique is garlic mustard (*Alliaria petiolate*). Typically, a Red Dragon propane vapor torch kit is used, with a propane tank weighing 8 to 20 lbs. The tank is attached to tubing and a wand with an adjustable valve at the tip. Torch treatment for garlic mustard is most successful for first year plants.

The treatment works best when applied after flowering season has begun and seeds begin to form; earlier treatments will cause garlic mustard to re-sprout. Second year garlic mustard plants are more successfully treated with herbicide. This is a technique that landowners could apply themselves with a permit, or you may choose to hire a land management consultant. Time and costs are variable, depending on the density of the invasive. Normal prescribed burn precautions should be taken, and high moisture days are best for this application – higher moisture than days selected for typical prescribed burns, without rain.

The greatest benefit of this technique is that it uses fire, a natural process. Almost all native Illinois woodland and prairie plants are adapted to fire. Fire provides an advantage for native plants, allowing them to maintain their population in the natural environment while controlling invasive plants. Herbicide treatment will kill all plants sprayed, including native plants, and leave a bare spot on the

ground that may promote and continue the cycle of the invasive.



Red Dragon Torch



I would like to thank Jaye Maxfield, Prescribed Fire Department Manager, Driftless Land Stewardship, for sharing her expertise with us. -- Susan



### Walnuts & Acorns

by Lee M. Rife

As I write this, summer is about 7 or 8 weeks away. Parts of the state are drenched, and others are dry. I have a news article from California with the headline "**Drought kills 12 million trees in California's national forests**". Researchers conducted an aerial survey of an 8.2 million acre forest in April and found approximately 999,000 dead trees. However, scientists said that there was not much that they could do about the situation. We in Illinois are fortunate that we do not have droughts that last for long periods of time. The worst that I recall here in Central Illinois was in 1988. We did lose a few trees due to stress, but nothing like that being reported in the Los Angeles Times article of May 5, 2015.

Some readers may say that what's happening in California doesn't affect us, but it does. When western wildfires use up their share of the Forest Service budget for fighting fires in that region, then the Forest Service must dip into the money budgeted for work in other

parts of the United States. Thus a long standing priority project in the Shawnee National Forest might be delayed again. Apparently there is some legislation being considered by the U. S. Congress that would stop the borrowing of funds from other forestry programs administered by the USDA Forest Service.

According to the April 29 edition of *Roll Call*, a bipartisan Wildfire Disaster Funding Act would treat wildfire like hurricanes, floods and other disasters, and the Forest Service would no longer have to dip into other funds when the firefighting budget was depleted. This would allow such programs as the Forest Stewardship program, the Forest Legacy program and others to move forward without mid-year cuts. This proposal has widespread bipartisan support west of the Mississippi, but not much support in the eastern US. We need to contact our federal Congresspersons to determine where they stand, and urge them to get on board if they do not have a position.

Information used in this commentary was provided by the American Forest Foundation, sponsor of the American Tree Farm System program.

## History of Conservation in Illinois

by Dave Gillespie, IFA Secretary

(Installment # 12)

This account of the history of conservation in Illinois was written by Joseph P. Schavilje in 1941. This installment begins where the eleventh installment ended.

William Blane made a tour of southern Illinois in 1822 while on his excursion through the United States and Canada. (Quaife, 1918) "In travelling through these prairies", he relates, "everyone must be struck with the vast number of a species of grouse, called "Prairie Fowls". They are delicious eating, and are killed in great numbers by the unrivalled marksmen of this country. I have seen at one time several hundred of prairie fowls in a flock. They would afford excellent sport to anyone who could procure a smooth bored gun. If a person with this sort of gun were adept in shooting, he might easily kill a hundred birds, or even more in a day."

Continued on Page 8

## Featured Tree

### Yellow Poplar - *Liriodendron tulipifera*

#### Alternate Names

tulip poplar, tulip magnolia, tulip tree, whitewood

#### Uses

The wood of tulip poplar is moderately light, soft, brittle, moderately weak, and is very easily worked. It is used for furniture stock, veneer and pulpwood.

Tulip poplar makes a desirable street, shade, or ornamental tree but the large size it attains makes it unsuited for many sites. Its good points for aesthetic use are: (1) rapid growth (2) pyramidal form (3) resistance to insect and disease damage (4) unusual leaves and attractive flowers, and (5) yellow autumnal color.

This species has some wildlife value. The fruits provide food for squirrels in the late fall and winter months, and the white-tailed deer often browse on the twigs.

Tulip poplar is planted for reforestation purposes because of its rapid growth and the commercial importance of its wood, and is often planted as an ornamental.

#### Description

Tulip poplar actually is not a poplar, but a member of the magnolia family. The leaves are tulip-shaped, alternate, and simple. The leaf is smooth on both surfaces, dark green and lustrous above, pale and often with a slight whitish bloom beneath.

Twigs are moderately stout, olive-brown, to reddish brown, very smooth and usually lustrous; the large terminal bud has two large duck-bill shaped scales.

Tulip poplar produces tulip-shaped, light greenish-yellow flowers from April to June. It is a prolific seed bearer but has a low percent germination. The cone shaped fruit clusters usually persist on branches. There are about 12,000 seeds per pound.

The bark on younger trunks and branches is quite smooth, light ashy-gray with very shallow, longitudinal, whitish furrows. With age the bark becomes very thick, having deep interlacing furrows and rather narrow rounded ridges.

This tree is rapid growing, attaining heights of 80-120 feet and a trunk diameter of 2 to 5 feet. Young trees have a pyramidal form. Tulip poplar and white pine were the largest trees in the eastern forest.

#### Adaptation

Tulip poplar is exacting in soil and moisture requirements. It does best on moderately moist, deep, well drained, loose textured soils; it rarely grows well in very dry or very wet situations. It will tolerate a pH of 4.5 to 7.5.

#### Establishment

Natural regeneration of tulip poplar is usually by stump sprouts and seed. Regeneration from seed requires a seedbed of mineral soil, adequate soil moisture, sufficient direct sunlight for

early growth; seedlings are intolerant of shade.

Forest plantings are planted at spacings ranging from 6' x 7' to 10' x 10'. One year old nursery grown seedlings are used.

#### Management

The rapid growth of tulip poplar can present a challenge to other tree species in a mixed stand. This should influence the numbers of tulip poplar included in a mixed planting for conservation purposes, and may require thinning to maintain the values provided by other species. Moderate thinnings at 8-10 year intervals are recommended for timber production.

#### Pests and Potential Problems

Tulip poplar is unusually free from insects and disease. The yellow-poplar weevil, nectria canker, and fusarium canker are three of the more important enemies of this species.

This species is prone to wind damage and ice damage in exposed situations.

Prepared By & Species Coordinator:  
John Dickerson, Northeast Plant  
Materials Specialist USDA NRCS New York  
State Office, Syracuse, New York

[http://plants.usda.gov/factsheet/pdf/fs\\_litu.pdf](http://plants.usda.gov/factsheet/pdf/fs_litu.pdf)

### History of Conservation in Illinois - *continued from page 7*

Mr. Blane goes on to tell about the blazing of trees to mark trails in the woods, which are essential to finding one's way about, the building of log cabins from native trees. Some of these are so gigantic that the labor of chopping them down would be immense. He, therefore, cuts off the bark in a belt about four or five inches wide, and this is called girdling. The tree dies, and the year after, when it is dry, it is set on fire and continues to burn slowly until gradually consumed. (Quaife, 1918)

(To be continued in the next issue of "The IFA Newsletter").



Photos: John Edgington and Stephanie Brown



## Featured Invasive Species Profile

by Chris Evans

### Oriental Bittersweet - *Celastrus orbiculatus*

Oriental bittersweet is a deciduous, climbing, woody vine that can cause serious damage to forests in Illinois. This vine can grow to lengths of 60 feet and grow throughout the canopies of trees. Vines can encircle trees and girdle them. It also can completely cover other vegetation and shade, out-compete and kill even large trees. The added weight to the trees increases susceptibility to ice storms and wind damage. Oriental bittersweet can shade and restrict growth of native understory species, shrubs, tree seedlings, and some native vines.

Oriental bittersweet can be dispersed widely and quickly due to the berries being eaten and spread by birds. It can invade a variety of habitats including open and young forests, meadows, glades, savannas, roadsides, fencerows, old home sites, and other disturbed areas. However, Oriental bittersweet is tolerant of shaded conditions and can invade relatively undisturbed forests.

Vines can grow to 4-6 inches in diameter and are gray to olive in color with whitish-gray, raised dots. The alternate leaves are typically nearly perfectly round, bluntly toothed, and light green in color, turning yellow in fall. Leaves on smaller vines often have a long point at the tip.

Small, inconspicuous flowers give way to round fruit which ripen to yellow-orange and split to reveal showy scarlet berries that persist into winter. It closely resembles the native American bittersweet (*Celastrus scandens*) but can be distinguished from it because American bittersweet has flowers and fruits only at the end of the vines rather than all along the stem as with Oriental bittersweet.

Bittersweet can be controlled through cut stump treatment of glyphosate or triclopyr or a basal bark application of triclopyr (ester) in oil. Take caution not to cut the stems without treating, because it will result in extensive root suckering. Low growing plants or root suckers can be treated with glyphosate as a foliar application. With any herbicide application, always read and follow the label information and check the label for recommended application rates.

### Forest Service Publishes Quick Guide on How to ID Common Oak Diseases

The U.S. Forest Service just released a publication to help people to spot visual differences between common diseases of oaks by looking at symptoms found on oak leaves, branches and trunks.

“How to Recognize Common Diseases of Oaks in the Midwest: A Quick Guide,” is a convenient reference for landowners and forest managers.

The Northeastern Area State & Private Forestry published the publication to help forestry professionals, forest woodland managers, and homeowners identify and manage the most common diseases of oak trees in Midwestern States.

“It compares and contrasts key features of each disease to help you distinguish one disease from another,” said Jill Pokony, a Forest Service plant pathologist and author of the publication. “Knowing what disease is present will help to determine what management options are appropriate.”

The USDA guide covers the most common oak diseases present in the Midwest, some of which can be easily confused with others. These diseases include: bur oak blight; anthracnose; oak wilt; oak leaf blister; bacterial leaf scorch; *Botryosphaeria* twig canker; and oak decline.

The 17-page [publication](#) includes dozens of full-color photos and illustrations to help people spot the different looks of one disease from the next as they appear on oak trees. It also includes a variety of diagnostic features for each disease:

- host range
- causal agent(s)
- symptom expression
- timing and distribution of symptoms within the tree
- impact on tree health
- pattern of tree damage on site, and
- general management options.

The publication is only available online in PDF format. It is designed to be downloaded and printed by individuals. To explore more Northeastern Area publications, visit: <http://www.na.fs.fed.us/pubs/index.shtm>



Red berries

Climbing up tree

Wrapping around trunk

Round leaves

## Wood Projects for Illinois Wildlife

### Purple Martin Houses

*The information and project plans in this article are protected by copyright and shared with permission from the Illinois Department of Natural Resources.*

Attracting purple martins is the ultimate challenge to a backyard bird enthusiast. Some people will put up a martin house in the spring and attract martins with relative ease. Other persons may maintain martin houses for years in apparently good habitat - with no luck in attracting them.

The purple martin is the largest member of the swallow family. It eats flying insects. Males are glossy black with purple iridescence. The markings of the female are somewhat duller.

The wooden purple martin house design should be modified to add a 1/2" diameter maple dowel "fence" around each balcony to prevent baby martins from falling off the balcony. If they fall to the ground, they will not be fed by their parents.

Following is an itemized list of instructions for making this purple martin house.

#### CONSTRUCTION

**NOTE:** This unit is held together by a threaded rod extending from the underside of the 1" x 2" base frame through the center of the chimney.

1. Mark all pieces on plywood sheet, then cut them out. Make four 1" x 1" x 5-7/8" corner blocks and eight 1" x 1" x 2" blocks to position the parts.
2. Cut out and assemble base from 1" x 2". Use 7d galvanized siding nails. Attach floor piece to base with glue and 1" or 1-1/4" nails.
3. Assemble the sides, alternating three-hole and one-hole pieces. Use glue and 1" nails or 3/4" #6 flat head wood screws. Place completed sides in position on floor. Insert partitions. Position ceiling and mark for the location of 1" x 1" x 2" blocks near corners on the underside. Attach the blocks.

4. Place ceiling in position.
5. Glue pairs of end roof supports together to form gable ends 1/2" thick. Attach screen. Position and mark. Glue the two center roof supports together to make it 1/2" thick. It will be positioned adjacent to the threaded rod going up through the exact center of the house. Attach these pieces to the ceiling with glue and nails or flat head screws from the underside. Attach roof sides with glue and nails or screws.
6. Make chimney from pieces of 2 x 2. Cut V-notch on end to fit roof. Have it extend 2-1/2" above roof peak. Drill 1/4" hole in chimney and roof rod. Nail chimney in place. Insert rod and tighten up.
7. Drill hole in top of pole to accommodate nut on lower end of threaded rod.
8. Use 1/2" diameter maple dowels to make a fence about 2" high on each balcony. Pieces of wood 1" x 1" x 3" may be used as the corner posts of the railing.

#### MOUNTING

Use four 4" x 5" shelf brackets with 1/4" or 3/16" x 1-1/2" round head stove bolts and 1" #8 flat head wood screws to attach to pole.

**NOTE:** Additional stories may be added if desired. One ceiling unit, four-sides, four-room partitions, eight 1" x 1" x 2" blocks and four 1" x 1" x 5-7/8" corner blocks will be needed for each additional story.

Do not paint the interior of the house. Lightweight roofing paper makes an efficient roof covering. When painting the house, use aluminum paint on the roofing paper before painting it white.

This seals in the black tar of the paper.

Commercially-made aluminum houses are acceptable if they are well-ventilated, have at least six compartments, with each compartment at least 6" x 6" x 6" in size. The entrance holes should be 2-1/4" in diameter and the bottom of the holes should be 1 inch above the floor.



Purple martins will arrive in southern Illinois in late March. As soon as the first martins, or "scouts", are seen, remove entrance covers from the martin houses.

The covers are used to keep sparrows and starlings out during the winter. If a cold spell hits after martins arrive, insects will die and the martins starve. To help, place crushed egg shells on a flat, elevated surface near the martin house. Another special inducement for the martins is a 1' x 2' area soaked, unsodded earth which provides them with a "mud puddle" for a water supply.

Purple martin houses should be placed in an open area where the birds have clear access from all sides. The house should be at least 30 feet away from trees. Martins seem to prefer sites where utility wires are nearby for perching. Houses near open water, like lakes, may have added appeal but this is not essential. Martin houses should be painted white or a light color to reflect the sun's heat.

Some people suggest placing purple martin houses very high - from 12 to 18 feet. However, other people suggest placing the house on a 4" x 4" cedar post no more than 8 to 10 feet high so it is easier to maintain during the summer with a step ladder. If in doubt, try using a 14' x 4" x 4" cedar post. Set it 4 feet deep in the ground and secure the base by pouring a small batch of concrete in the post hole before filling the post hole.

A martin house can be taken down, cleaned and stored at the end of the summer, or the entrances should be covered as soon as the martins leave in late August to early September. If martin house is left up, the nesting cavities still need to be cleaned out.

You can access a scanned copy of "Wood Projects for Illinois Wildlife" at <http://www.dnr.illinois.gov/publications/Documents/00000211.pdf>.

See house plans on page 11



# Nest Box 5

## PURPLE MARTIN HOUSE

**MATERIALS:**  
 4' x 8' x 1/4" PLYWOOD  
 2" x 2" x 6" FOR CHIMNEY  
 1" x 2" x 14' (BASE)  
 1" x 1" x 8" (CORNER BLOCKS)  
 4" x 8" METAL WINDOW SCREEN  
 4" x 4" x 14' CEDAR POST

(NOT SHOWN)  
 PLACE 1/2" DOWEL  
 RAILING AROUND  
 BALCONY TO KEEP  
 YOUNG FROM FALLING

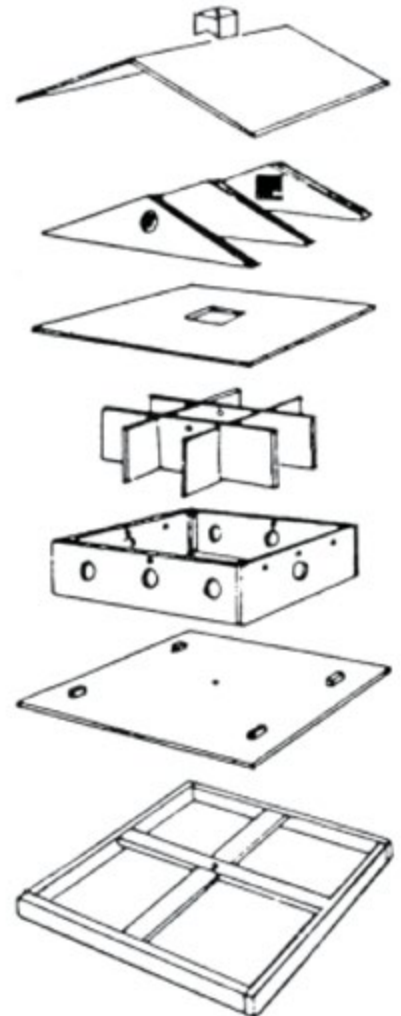
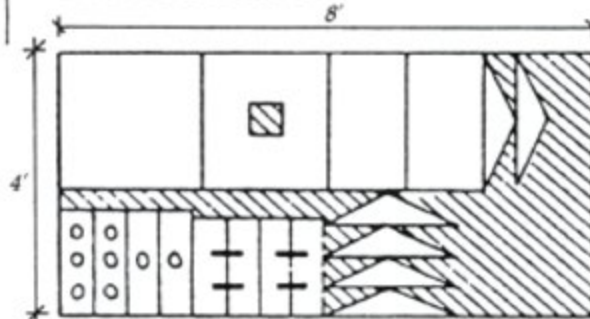

EXPANDED VIEW OF MARTIN HOUSE. A THREADED ROD INSERTS THROUGH THE BASE AND UP THROUGH THE CHIMNEY

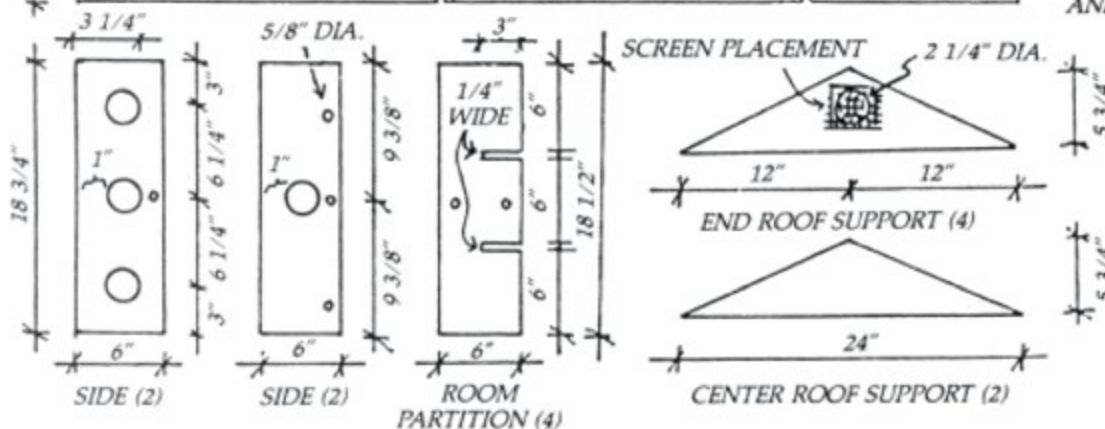
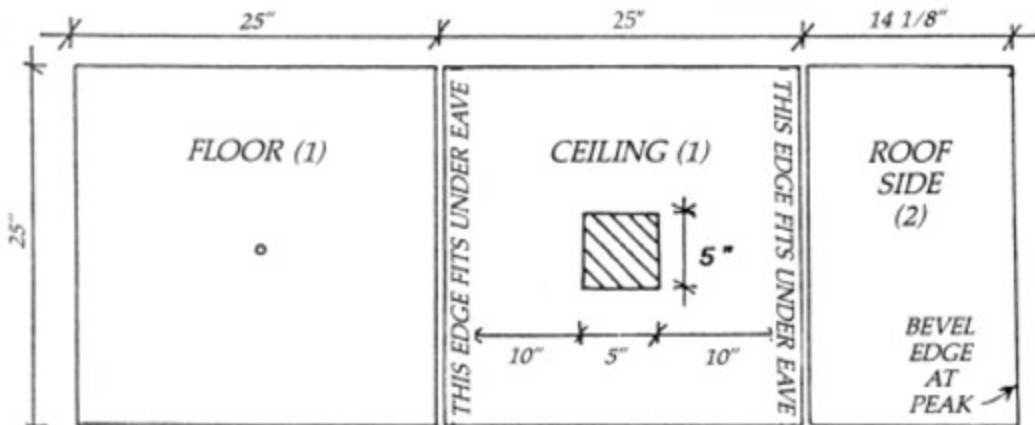

ENTRANCE HOLE  
 DIAMETER  
 2 1/4"

LOCATE 5/8"  
 VENTILATION HOLES  
 1" BELOW TOP  
 EDGE OF SIDES

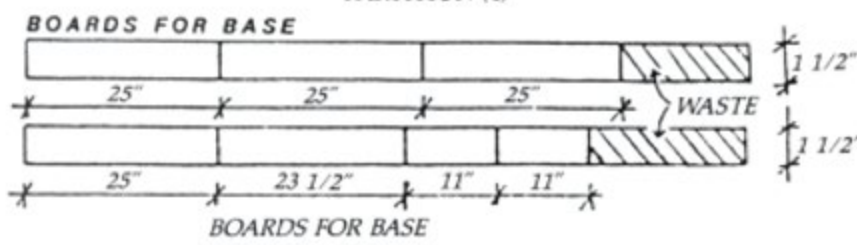

NOTE: THIS PLAN IS FOR A ONE-STORY HOUSE. TO ADD A SECOND STORY, MAKE ONE MORE CEILING UNIT (25" x 25"), FOUR MORE SIDES, AND FOUR MORE ROOM PARTITIONS.



Illinois Forestry Association  
P.O. Box 224  
Chatham, IL 62629-0224

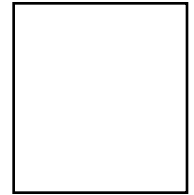

*Join Us in Effingham - September 25-26 - for the 2015 IFA Annual Meeting and Tree Farm Field Day*

**Forestry Word Search -- "Forest Management Plan"**

<b>BASAL AREA</b>	I G W R U A N A D W T H W I O S K P Q Y
<b>BMP</b> (Best Management Practice)	L N N C I N O N N J A K N W O D O R G R
<b>BOUNDARY</b>	T O V I X P V I N R D B R L L O E E I A
<b>CANOPY</b>	H S C E T D A T T D C L F M E V N S M D
<b>DEN TREES</b>	I L L A N N L R S G I J V F P C F C N N
<b>FENCING</b>	N N D P T T A T I U N D E R S T O R Y U
<b>FOREST TYPE</b>	N A L T G I O L B A G I S K N Q E I H O
<b>HABITAT</b>	I A I S T C O R P W N E C P H F Z B G B
<b>HARVEST</b>	N I K T K T Q N Y E V B K N O H X E B C
<b>INVASIVE</b>	G E F I L D L I W I E Q U R E F M D A T
<b>INVENTORY</b>	X B N H K V R M T Z W R E F P F Z B S E
<b>LOCATION</b>	S G B G S P E C I E S S T W F D W U A P
<b>OBJECTIVES</b>	R E C O M M E N D A T I O N S E S R L Y
<b>PRESCRIBED BURN</b>	T C E J D J I N V A S I V E S C R N A T
<b>RECOMMENDATIONS</b>	A A J R B K S S T S E V R A H D R A R T
<b>REFORESTATION</b>	T N P O T N O I T A R E N E G E R K E S
<b>REGENERATION</b>	I O V M S N O P W A C B D K B W D J A E
<b>RIPARIAN BUFFER</b>	B P D B B N E M R F N U Z P B A Y S Z R
<b>SCHEDULE</b>	A Y Y K V G H D A J L D Y U C N I J M O
<b>SPECIES</b>	H J G F E X W X W E N D S D H L G G S F
<b>STAND</b>	
<b>STOCKING</b>	
<b>THINNING</b>	
<b>TREE PLANTING</b>	
<b>TSI</b> (Timber Stand Improvement)	
<b>UNDERSTORY</b>	
<b>WILDLIFE</b>	